

TRIM

Version

Wall 90 - Black Glass - 800 m³/h

Collection

Design

EAN code

8034122358314

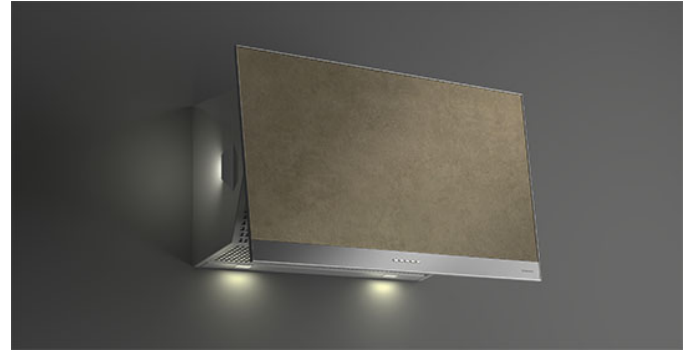

*The photograph is purely for information
It may not correspond to the selected version.*

FEATURES

Scotch brite stainless steel (AISI 304)
Front frame stainless steel (AISI 304)
Electronic control
LED ambient light
LED lighting
Top filter, removable and washable
Charcoal filter included
Possible to duct wall mounted from rear
Optional Chimney
Opening frontal

OPTIONAL ACCESSORIES

KACL.798#41F
Remote under-roof motor 950 m³/h
KACL.770#41F
Remote under-roof 1100 m³/h
Brushless
KACL.786#41F
Outdoor extractor fan 1000 m³/h
KACL.796#4AF
Outdoor extractor fan 1500 m³/h
KACL.797#4AF
Remote under-roof motor 1300 m³/h
KACL.941
External filter unit for sloped hoods

TECHNICAL FEATURES

Installation type
Wall
Dimensions
90 cm
Finishing
Black tempered glass
Motor
800 m³/h
Type of control
Electronic control
Speed settings
4
Lighting
Led 4x1,2 W - 3200 K
Ambient lighting
Led 2x1,2 W - 3200 K
Filter
Metallic filter "Top" - Tab 60
Charcoal filter
Round charcoal filter Ø170 mm - Type 6
Minimum distance
Gas hob: 52 cm
Electric hob: 52 cm

PACKAGING:WEIGHTS AND VOLUMES

Gross weight
29.00 kg
Net weight
24.60 kg
Volume
0.28 m³
Packaging size
Length
995 mm
Height
595 mm
Depth
480 mm

CONSUMPTION AND CONNECTION FEATURES

Maximum consumption
280 W
Voltage / Frequency
220-240V

50-60Hz

MOTOR TECHNICAL SHEET

Maximum capacity
750 m³/h
I.E.C. 61591
Maximum noise level
66 dB(A)re1pW
I.E.C.60704-2-13
Maximum pressure (Pa)
510 Pa
Max. motor power
224 W
ENERGY CLASS
A

TRIM

Version

Wall 90 - Black Glass - 800 m³/h

Collection

Design

EAN code

8034122358314

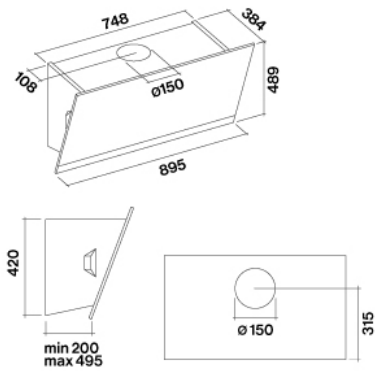

TRIM

Version

Wall 90 - Black Glass - 800 m³/h

Collection

Design

EAN code

8034122358314

MOTOR TECHNICAL SHEET

Motor speed	1	2	3	4
Noise level dB(A)re1pW-I.E.C.60704-2-13	46	53	58	66
Capacity (m3/h) I.E.C.61591 Normalized Pipes	295	390	500	750
Maximum pressure (Pa)	390	440	490	510
Motor Power (W)	130	150	178	224
Air outlet	150	150	150	150

CAPACITY / PRESSURE



TRIM

Version

Wall 90 - Black Glass - 800 m³/h

Collection

Design

EAN code

8034122358314

ENERGY LABEL

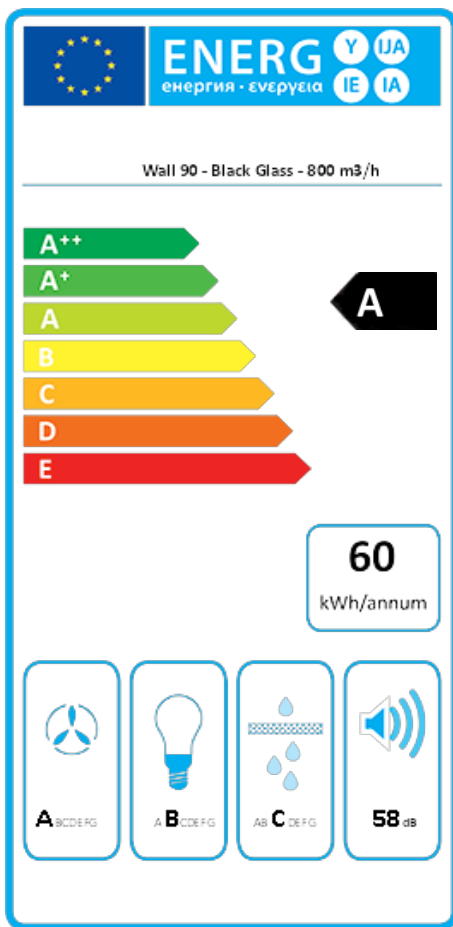

PF		
S	Falmec Spa	
M	Wall 90 - Black Glass - 800 m ³ /h	
AEC	60,4	kWh/a
ECC	A	
FDE	29,8	
FDEC	A	
LE	26,9	
LEC	B	
GFE	82,0	
GFEC	C	
Qmin	295,0	m ³ /h
Qmax	500,0	m ³ /h
Qboost	750,0	m ³ /h
SPEmin	46	dBa
SPEmax	58	dBa
SPEboost	66	dBa
PO	-	W
PS	0,48	W
PI		
F	0,9	
EEl	54,7	
Qbep	432,0	m ³ /h
Pbep	407	Pa
Qboost	750,0	m ³ /h
Wbep	164,0	W
WL	9,00	W
Emiddle	242	lux
Lwa-SPEmax	58	dBa

PF_Product fiche according to 65/2014 S_Supplier name / M_Model identification / AEC_Annual Energy Consumption (AEC hood) / EEC_Energy Efficiency class / FDE_Fluid Dynamic Efficiency (FDE hood) / FDEC_Fluid Dynamic Efficiency class / LE_Lighting Efficiency (LE hood) / LEC_Lighting Efficiency class / GFE_Grease Filtering Efficiency / GFEC_Grease Filtering Efficiency class / Qmin_Air flow (in m³/h) at min speed in normal use / Qmax_Air flow (in m³/h) at max speed in normal use / Qboost_Air flow (in m³/h) at intensive or boost setting (max air-flow) / SPEmin_Airborne acoustical A-weighted sound power emissions at min speed in normal use / SPEmax_Airborne acoustical A-weighted sound power emissions at max speed in normal use / SPEboost_Airborne acoustical A-weighted sound power emissions (in dB) at intensive or boost setting / PO_Power consumption in off mode (Po) / Ps_Power consumption in stand by mode (Ps). **PI_Additional information according to 66/2014** F_Time increase factor / EEl_Energy Efficiency Index / Qbep_Measured air flow rate at best efficiency point / Pbep_Measured air pressure at best efficiency point / Qboost_Maximum air flow / Wbep_Measured electric power input at best efficiency point / WL_Nominal power of the lighting system / Emiddle_Average illumination of the lighting system on the cooking surface / Lwa=SPEmax_Sound pressure level at the highest speed.