

VIRGOLA PLUS

Version

FDVRG36W3SS/ Built-in – 36"
(90 cm) 280 CFM

Collection

Design

EAN code

8034122346489



Photograph is for information purposes only
May not correspond to the selected version

FEATURES

Slide out glass panel
Electronic control
Metallic grease filter, removable
and washable
Charcoal filter (optional)
Scotch brite stainless steel
Dynamic Light (2700K - 5600K)

Recommended mounting height
from cooking surface to hood
bottom: 24" - 35"

OPTIONAL ACCESSORIES

FFCHASQCOBL

FFCHASQCOBL - Square
charcoal filter - Type 3

KACL.815

Protective cleaning cloths for
stainless steel (box 10 pcs)

KACL.950

Filter unit for built-in hoods

KCVJN.00#3

KIT CHIMNEY VIRGOLA-MOVE
H=185 + Ext. H=185 Stainless
Steel

KCVJN.01#3

Kit Chimney Virgola-Move H120
Stainless Steel

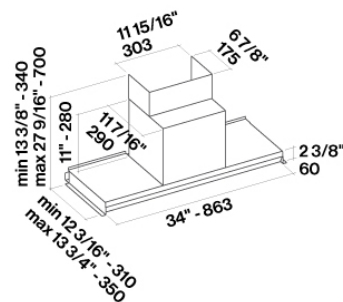

TECHNICAL FEATURES

Installation type

Built-in

Dimensions

90 cm

Finish

Scotch brite stainless steel

Motor

450 m³/h

Type of control

Electronic control

Speed

3

Filter

4 x Metallic filter "Base" -
245x207 mm

Charcoal filter

FFCHASQCOBL - Square
charcoal filter - Type 3 (optional)

Minimum distance

Gas hob: 52 cm

Electric hob: 52 cm

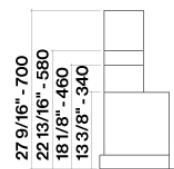

Optional chimney

PACKAGING:WEIGHTS AND VOLUMES

Gross weight

15 kg

Net weight

11.6 kg

Volumes

0.19 m³

Packaging size

Length

995 mm

Height

410 mm

Depth

465 mm

CONSUMPTION AND CONNECTION FEATURES

Maximum consumption

150 W

Plug type

Hood comes standard with Nema
5-15P power cord

ENERGY CLASS