

## VIRGOLA PLUS

### Version

FDVRG24W3SS / Built-in - 24"  
(60 cm) 280 CFM

### Collection

Design

### EAN code

8034122346472



Photograph is for information purposes only  
May not correspond to the selected version

## FEATURES

Slide out glass panel  
Electronic control  
Metallic grease filter, removable  
and washable  
Charcoal filter (optional)  
Dynamic Light (2700K - 5600K)

## OPTIONAL ACCESSORIES

### FFCHASQCOBL

FFCHASQCOBL - Square  
charcoal filter - Type 3

### KACL.815

Protective cleaning cloths for  
stainless steel (box 10 pcs)

## TECHNICAL FEATURES

### Installation type

Built-in

### Dimensions

60 cm

### Finish

Scotch brite stainless steel

### Motor

450 m<sup>3</sup>/h

### Type of control

Electronic control

### Speed

3

### Lighting

Led 2x1,2 W - 3200 K

### Filter

2 x Metallic filter "Base" -  
245x207 mm

### Charcoal filter

FFCHASQCOBL - Square  
charcoal filter - Type 3 (optional)

### Minimum distance

Gas hob: 52 cm

Electric hob: 52 cm

## PACKAGING:WEIGHTS AND VOLUMES

### Gross weight

11.9 kg

### Net weight

9.2 kg

### Volumes

0.13 m<sup>3</sup>

### Packaging size

Length

705 mm

Height

410 mm

Depth

465 mm

## CONSUMPTION AND CONNECTION FEATURES

### Maximum consumption

150 W

### Plug type

Hood comes standard with Nema  
5-15P power cord

### ENERGY CLASS

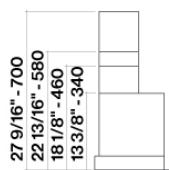
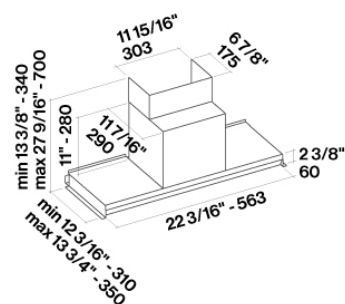

Optional chimney