

POLAR

Version

FDPLR15I5SS-R / Island – 15"
(40 cm) 500 CFM

Collection

Design

EAN code

8034122331393



Photograph is for information purposes only
May not correspond to the selected version

FEATURES

Scotch brite stainless steel (AISI 304)

Electronic control

LED lighting

Top filter, removable and washable

Charcoal filter (optional)

SRS Speed reduction system

Recommended mounting height from cooking surface to hood bottom: 24" - 35"

OPTIONAL ACCESSORIES

FDNUMTR600

FDNUMTR600 - Motor 600 CFM for North America

FFCHAR3C0BL

FFCHAR3C0BL - Round charcoal filter Ø 6" - Type 6

KACL.802

Glass island

KACL.815

Protective cleaning cloths for stainless steel (box 10 pcs)

TECHNICAL FEATURES

Installation type

Island

Dimensions

15 / 35 cm

Finish

Scotch brite stainless steel (AISI 304)

Motor

500 CFM

Type of control

Electronic control

Speed

4

Lighting

Led 3x1,2 W - 3200 K

Charcoal filter

FFCHAR3C0BL - Round charcoal filter Ø 6" - Type 6 (optional)

Minimum distance

Gas hob: 24 in

Electric hob: 21 in

PACKAGING:WEIGHTS AND VOLUMES

Gross weight

64 lbs

Net weight

53 lbs

Volumes

11 ft³

Packaging size

Length

40 in

Height

20 in

Depth

24 in

CONSUMPTION AND CONNECTION FEATURES

Maximum consumption

280 W

Plug type

Hood comes standard with Nema 5-15P power cord

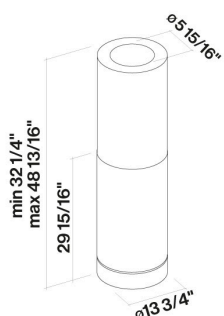
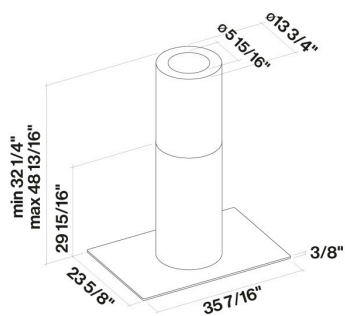

Hood with optional glass
(FDPGL36I0TG)