

## LUMINA NRS

### Version

FNLUM36I5SS / Island – 36" (90 cm) Steel – 500 CFM

### Collection

Silence - NRS

### EAN code

8034122347226

## FEATURES

**Scotch brite stainless steel (AISI 304)**

**Tempered glass with steel look finish**

**NRS technology for a quieter kitchen**

**Touch control + 24 h function**

**Fluorescent ambient light**

**Metallic grease filter, removable and washable**

**Optional charcoal filter**

## OPTIONAL ACCESSORIES

### KACL.572#1

Extension H1200 - Island

### KACL.815

Protective cleaning cloths for stainless steel (box 10 pcs)

### KACL.400

Silent / Conveyor NRS

### 101078900

High performance filter

## TECHNICAL FEATURES

### Installation type

Island

### Dimensions

36 " / 90 "

### Finish

Scotch brite stainless steel (AISI 304)

Tempered glass with white finish

### Motor

500 CFM

### Type of control

Touch control

### Speed settings

4

### Filter

Metallic filter "Base" - 274x274 mm - 2 pz

### Minimum distance

Gas hob: 26 in

Electric hob: 21 in

## PACKAGING:WEIGHTS AND VOLUMES

### Gross weight

115 lbs

### Net weight

100 lbs

### Volume

22 ft<sup>3</sup>

### Packaging size

Length

43 in

Height

35 in

Depth

26 in

## CONSUMPTION AND CONNECTION FEATURES

### Maximum consumption

340 W

### Voltage / Frequency

120V 60Hz

### Plug type

Standard

## MOTOR TECHNICAL SHEET

### Maximum capacity

610 m<sup>3</sup>/h

I.E.C. 61591

### Maximum noise level

54,5 dB(A)re1pW

I.E.C.60704-2-13

### Maximum pressure (Pa)

510 Pa

### Max. motor power

224 W

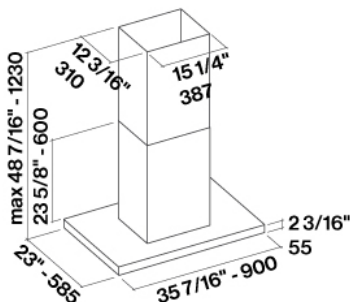

## LUMINA NRS

### Version

FNLUM36I5SS / Island – 36" (90 cm) Steel – 500 CFM

### Collection

Silence - NRS

### EAN code

8034122347226

## MOTOR TECHNICAL SHEET

Motor Speed	1	2	3	4
Noise level dB(A)re1pW-I.E.C.60704-2-13	37	41	46	54,5
Capacity (m3/h) I.E.C.61591 Normalized Pipes	220	290	375	610
Maximum pressure (Pa)	390	440	490	510
Motor Power (W)	130	150	178	224
Air outlet	150	150	150	150