

ALBA

Version

Remote under-roof motor 950
m³/h

Collection

Design+

EAN code

8034122359526



*The photograph is purely for information
It may not correspond to the selected version.*

FEATURES

Perimeter suction
Electronic control
Metallic grease filter,
removable and washable
Remote control included
Perimeter Led Lighting
Glass perimeter frame
Matte white painted panel
Possibility of painting the panel

OPTIONAL ACCESSORIES

KACL.782#49F

Slim motor 800 m³/h

KACL.786#41F

Outdoor extractor fan 1000
m³/h

KACL.796#4AF

Outdoor extractor fan 1500 m³/h

KACL.797#4AF

Remote under-roof motor 1300
m³/h

KACL.798#41F

Remote under-roof motor 950
m³/h

TECHNICAL FEATURES

Installation type

Ceiling

Dimensions

120 cm

Finishing

Electronic control

Type of control

Electronic control

Speed settings

4

Lighting

LED (4000 K)

PACKAGING:WEIGHTS AND VOLUMES

ALBA Gross weight

52.2 kg

Net weight

45.2 kg

Volumes

0.37 m³

Packaging size

Length

1395 mm

Height

310 mm

Depth

865 mm

REMOTE MOTOR Remote
under-roof motor 950 m³/h

Gross weight

10 kg

Net weight

9 kg

Volumes

0.06 m³

Packaging size

Length

435 mm

Height

340 mm

Depth

385 mm

CONSUMPTION AND CONNECTION FEATURES

Maximum consumption

90 W

Voltage

220-240V

Frequency

50-60Hz

ENERGY CLASS

0

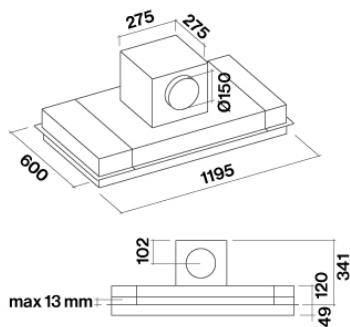

Hood and motor dimensions