

MOVE

Version

Built-in 120 cm - Black - 800 m³/h

Collection

Design

EAN code

8034122353326



The photograph is purely for information
It may not correspond to the selected version.

FEATURES

Scotch brite stainless steel (AISI 304)
Lower part in black tempered glass
Sliding door
Electronic control
Metallic grease filter, removable and washable
Optional combined regenaleble Carbon.Zeo filter
Possible to duct wall mounted from rear
Optional Chimney
Optional glass shelf
Dynamic LED Light (2700K - 5600K)

Control: indication of controls on the frontal panel (The control is in the upper side).

OPTIONAL ACCESSORIES

KACL.934

Carbon.Zeo filters

KACL.815

Protective cleaning cloths for stainless steel (box 10 pcs)

KACL.798#41F

Remote under-roof motor 950 m³/h

KACL.770#41F

Remote under-roof 1100 m³/h
Brushless

KACL.786#41F

Outdoor extractor fan 1000 m³/h

KACL.796#4AF

Outdoor extractor fan 1500 m³/h

KACL.797#4AF

Remote under-roof motor 1300 m³/h

TECHNICAL FEATURES

Installation type

Built-in

Dimensions

120 cm

Finishing

Scotch brite stainless steel (AISI 304)

Lower part in black tempered glass

Motor

800 m³/h

Type of control

Electronic control

Speed settings

4

Lighting

Led 3x1,2 W - 2700 K / 5600 K

Filter

Metallic filter "Base" - 198x161 mm - 2 pz

Charcoal filter

Carbon.Zeo filters

Minimum distance

Gas hob: 52 cm

Electric hob: 52 cm

PACKAGING:WEIGHTS AND VOLUMES

Gross weight

24.10 kg

Net weight

20.00 kg

Volume

0.24 m³

Packaging size

Length

1295 mm

Height

465 mm

Depth

395 mm

CONSUMPTION AND CONNECTION FEATURES

Maximum consumption

280 W

Voltage / Frequency

220-240V

50-60Hz

Plug type

Shuko

MOTOR TECHNICAL SHEET

Maximum capacity

680 m³/h

I.E.C. 61591

Maximum noise level

68 dB(A)re1pW

I.E.C.60704-2-13

Maximum pressure (Pa)

500 Pa

Max. motor power

215 W

ENERGY CLASS

B

MOVE

Version

Built-in 120 cm - Black - 800 m³/h

Collection

Design

EAN code

8034122353326

Hood and rear view

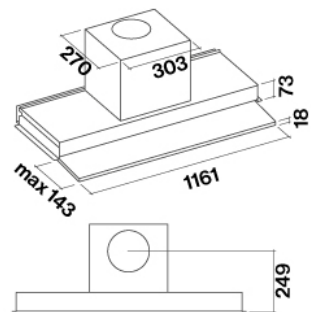

Optional chimney

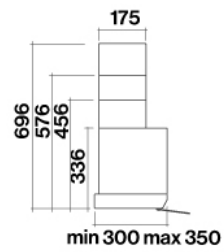

Optional shelf

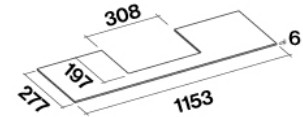

MOVE

Version

Built-in 120 cm - Black - 800 m³/h

Collection

Design

EAN code

8034122353326

MOTOR TECHNICAL SHEET

Motor speed	1	2	3	4
Noise level dB(A)re1pW-I.E.C.60704-2-13	49	56	62	68
Capacity (m ³ /h) I.E.C.61591 Normalized Pipes	280	370	480	680
Maximum pressure (Pa)	390	420	480	500
Motor Power (W)	132	153	175	215
Air outlet	150	150	150	150

CAPACITY / PRESSURE

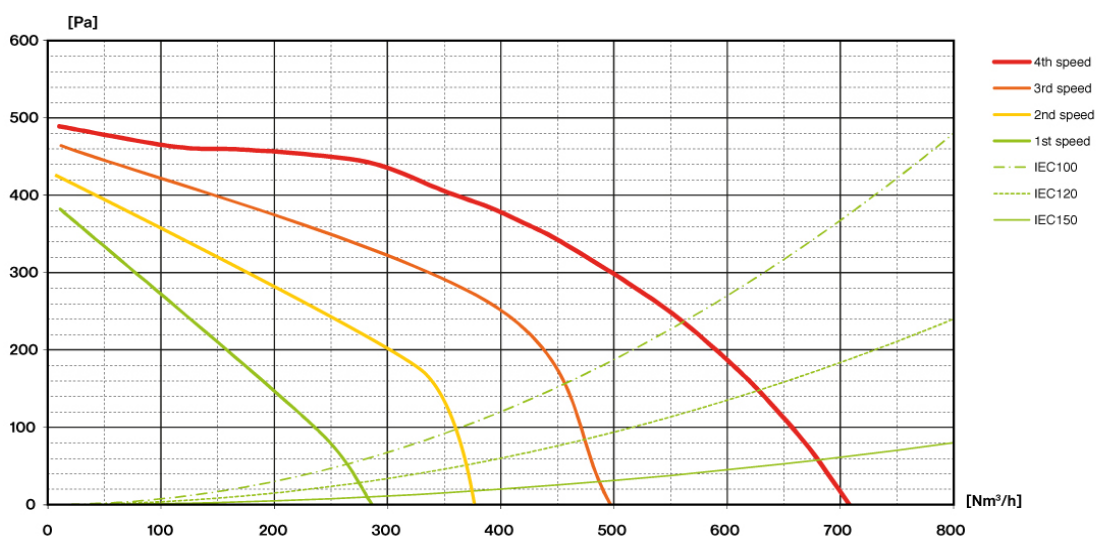

MOVE

Version

Built-in 120 cm - Black - 800 m³/h

Collection

Design

EAN code

8034122353326

ENERGY LABEL

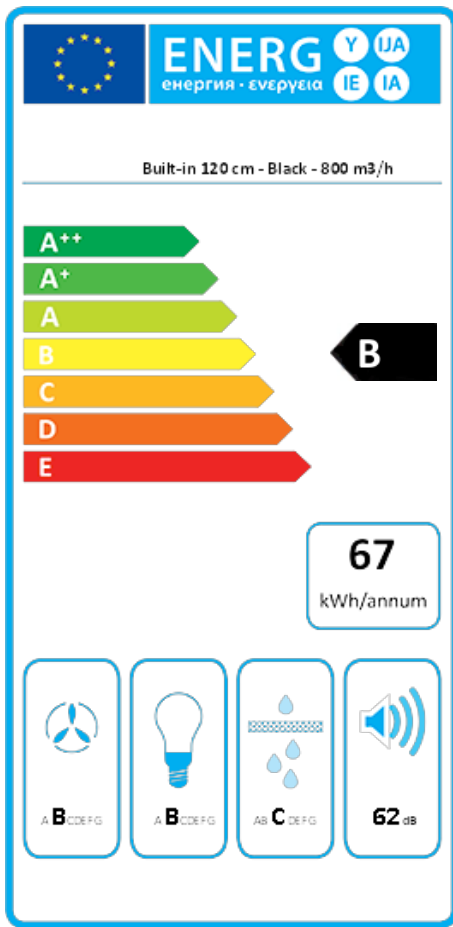

PF		
S	Falmec Spa	
M	Built-in 120 cm - Black - 800 m ³ /h	
AEC	67,0	kWh/a
ECC	B	
FDE	26,3	
FDEC	B	
LE	20,7	
LEC	B	
GFE	80,0	
GFEC	C	
Qmin	280,0	m ³ /h
Qmax	480,0	m ³ /h
Qboost	680,0	m ³ /h
SPEmin	49	dBa
SPEmax	62	dBa
SPEboost	68	dBa
PO	-	W
PS	0,48	W
PI		
F	1,1	
EEl	64,3	
Qbep	382,0	m ³ /h
Pbep	384	Pa
Qboost	680,0	m ³ /h
Wbep	155,1	W
WL	6,50	W
Emiddle	134	lux
Lwa-SPEmax	62	dBa

PF_Product fiche according to 65/2014 S_Supplier name / M_Model identification / AEC_Annual Energy Consumption (AEC hood) / EEC_Energy Efficiency class / FDE_Fluid Dynamic Efficiency (FDE hood) / FDEC_Fluid Dynamic Efficiency class / LE_Lighting Efficiency (LE hood) / LEC_Lighting Efficiency class / GFE_Grease Filtering Efficiency / GFEC_Grease Filtering Efficiency class / Qmin_Air flow (in m³/h) at min speed in normal use / Qmax_Air flow (in m³/h) at max speed in normal use / Qboost_Air flow (in m³/h) at intensive or boost setting (max air-flow) / SPEmin_Airborne acoustical A-weighted sound power emissions at min speed in normal use / SPEmax_Airborne acoustical A-weighted sound power emissions at max speed in normal use / SPEboost_Airborne acoustical A-weighted sound power emissions (in dB) at intensive or boost setting / PO_Power consumption in off mode (Po) / Ps_Power consumption in stand by mode (Ps). **PI_Additional information according to 66/2014** F_Time increase factor / EEl_Energy Efficiency Index / Qbep_Measured air flow rate at best efficiency point / Pbep_Measured air pressure at best efficiency point / Qboost_Maximum air flow / Wbep_Measured electric power input at best efficiency point / WL_Nominal power of the lighting system / Emiddle_Average illumination of the lighting system on the cooking surface / Lwa=SPEmax_Sound pressure level at the highest speed.