

NUVOLA 90

Version

FDNUMVTR600 - Motor 600
CFM for North America

Collection

Design+

EAN code

8034122353142

FEATURES

- Perimeter suction
- Electronic control
- LED lighting
- Metallic grease filter, removable and washable
- Remote control included
- Motor sold separately
- SRS Speed reduction system

Recommended mounting maximum distance from cooking surface to hood bottom: 150cm (59")

OPTIONAL ACCESSORIES

FDNUMVTR600

FDNUMVTR600 - Motor 600
CFM for North America

KACL.396

Ø200 - Flange

KACL.398

Ø150 - Flange

KACL.928

Filters spare

KACL.931

Carbon.Zeo filter spare part (vertical outlet)

KACL.939#BF

Ceiling re-circulation filtering kit

KACL.953#BF

Carbon.Zeo vertical outlet ceiling filter unit kit

105080053

Remote control

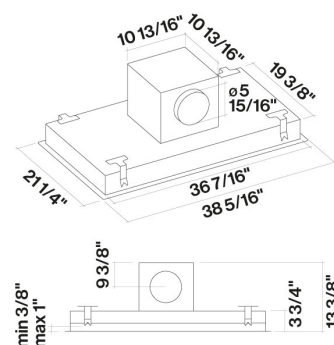

Hood with motor

TECHNICAL FEATURES

Installation type

Ceiling

Dimensions

36 / 90 cm

Finish

Scotch brite stainless steel (AISI 304)

Motor

CFM

Type of control

Electronic control

Speed settings

4

Lighting

LED (4000 K)

Filter

3 x Metallic filter "Base" - 290x267 mm

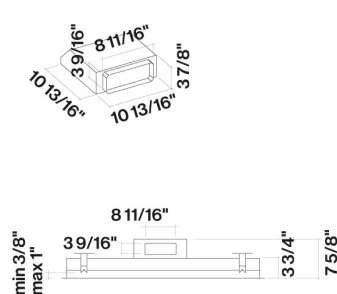

Side view with junction (optional)



Photograph is for information purposes only
May not correspond to the selected version

PACKAGING:WEIGHTS AND VOLUMES

NUVOLA 90 Gross weight

58 lbs

Net weight

52 lbs

Volumes

5 ft³

Packaging size

Length

45 in

Height

8 in

Depth

27 in

REMOTE MOTOR

FDNUMVTR600 - Motor 600

CFM for North America

Gross weight

23 lbs

Net weight

20 lbs

Volumes

3 ft³

Packaging size

Length

18 in

Height

14 in

Depth

16 in

CONSUMPTION AND CONNECTION FEATURES

Maximum consumption

340 W

Plug type

Hood comes standard with Nema 5-15P power cord

ENERGY CLASS