

NUVOLA 140

Version

FDNUVMTR600 - Motor 600
CFM for North America

Collection

Design+

EAN code

8034122345017



Photograph is for information purposes only
May not correspond to the selected version

FEATURES

Scotch brite stainless steel (AISI 304)
Perimeter suction
Electronic control
LED lighting
Metallic grease filter, removable and washable
Remote control included
Motor sold separately

OPTIONAL ACCESSORIES

105080053

Remote control

FDNUVMTR600

FDNUVMTR600 - Motor 600
CFM for North America

KACL.815

Protective cleaning cloths for stainless steel (box 10 pcs)

TECHNICAL FEATURES

Installation type

Ceiling

Dimensions

140 cm

Finish

Scotch brite stainless steel (AISI 304)

Tempered extra light white glass finishing

Motor

600 CFM - 1000 m³/h

Type of control

Electronic control

Speed

4

Filter

4 x Metallic filter "Base" -
290x267 mm

PACKAGING:WEIGHTS AND VOLUMES

NUVOLA 140 Gross weight

40 kg

Net weight

35 kg

Volumes

0.22 m³

Packaging size

Length

1455 mm

Height

210 mm

Depth

730 mm

REMOTE MOTOR

FDNUVMTR600 - Motor 600
CFM for North America

Gross weight

10 kg

Net weight

9 kg

Volumes

0.06 m³

Packaging size

Length

435 mm

Height

340 mm

Depth

385 mm

CONSUMPTION AND CONNECTION FEATURES

Maximum consumption

340 W

Plug type

Hood comes standard with Nema
5-15P power cord

ENERGY CLASS

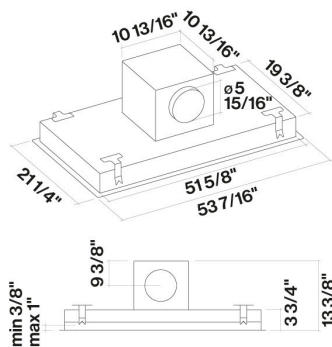

Hood with motor

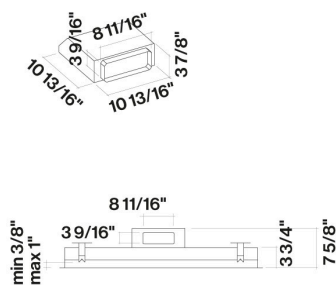

Side view with junction (optional)